

12 - 2006 | S. AG.

Ed. 2004

1 - Hood / Tank

CODE	DESCRIPTION
120356	DOOR MAGN.SWITCH
150819	CABLE HOLDER PG16 WITH HOLE
160509	FOOT SUPPORT
160720	PLUG HEYCO D.8
180506	DOOR CATCH BR-BC-FC
210203	RUBBER FOOT 30 MM
260114	SCREW TE 8X25
260238	M4 X 10 MUSH/HD SCREW
260248	SPECIAL SCREW TB 5X12
260404	STAINLESS STEEL NUTS D6 UNI 55
260412	SELF-LOCKING NUT M6
260415	STAINLESS STEEL SELF-LOCKING N
260431	NUT M5 DIN 6923
260504	ST/ST FLAT WASHER D6
260505	STAINL.STEEL FLAT WASHER D8
260713	SCREW 3,9X16
450821	SPRING CLIP FASTENER SNU 3634
450830	SCREW
450831	SCREW SUPPORT
450905	CAPIL.THERMOMETER D.52 1,5M
460344	PLATE
H15568	DOOR PIN FOR DOOR GF70/90
H15995	BUSH
H25006	NUT FOR HOSE H26556
H25202	PAD FOR DOOR GF90
H25697	SCREW
H25700	SCREW TC 4X8
H26556	HOSE
H26751	SCREW TC 6X12
H30438	SPRING
H32969	DOOR MAGNET
H33277	SCREW TSP 2,9X9,5
H34408	BASEMENT FOR GF90
H34409	HOOD GF90
H34437	BACK COVER GF90
H34438	LOWER BACK PANEL
H34445	CONNECTOR GF90
H34773	DOOR SPRING GF90
H34774	TIE ROD FOR DOOR SPRING GF90
H35144	HOOD
H35167	UPPER COVER GF90
H35264	RIGHT RACK GUIDE GF90
H35265	LEFT RACK GUIDE GF90
H36004	PAD FOR DOOR GF90
H36734	PANEL FOR DOOR GF90
H37061	FRONT PANEL
H37062	PANEL FOR DOOR

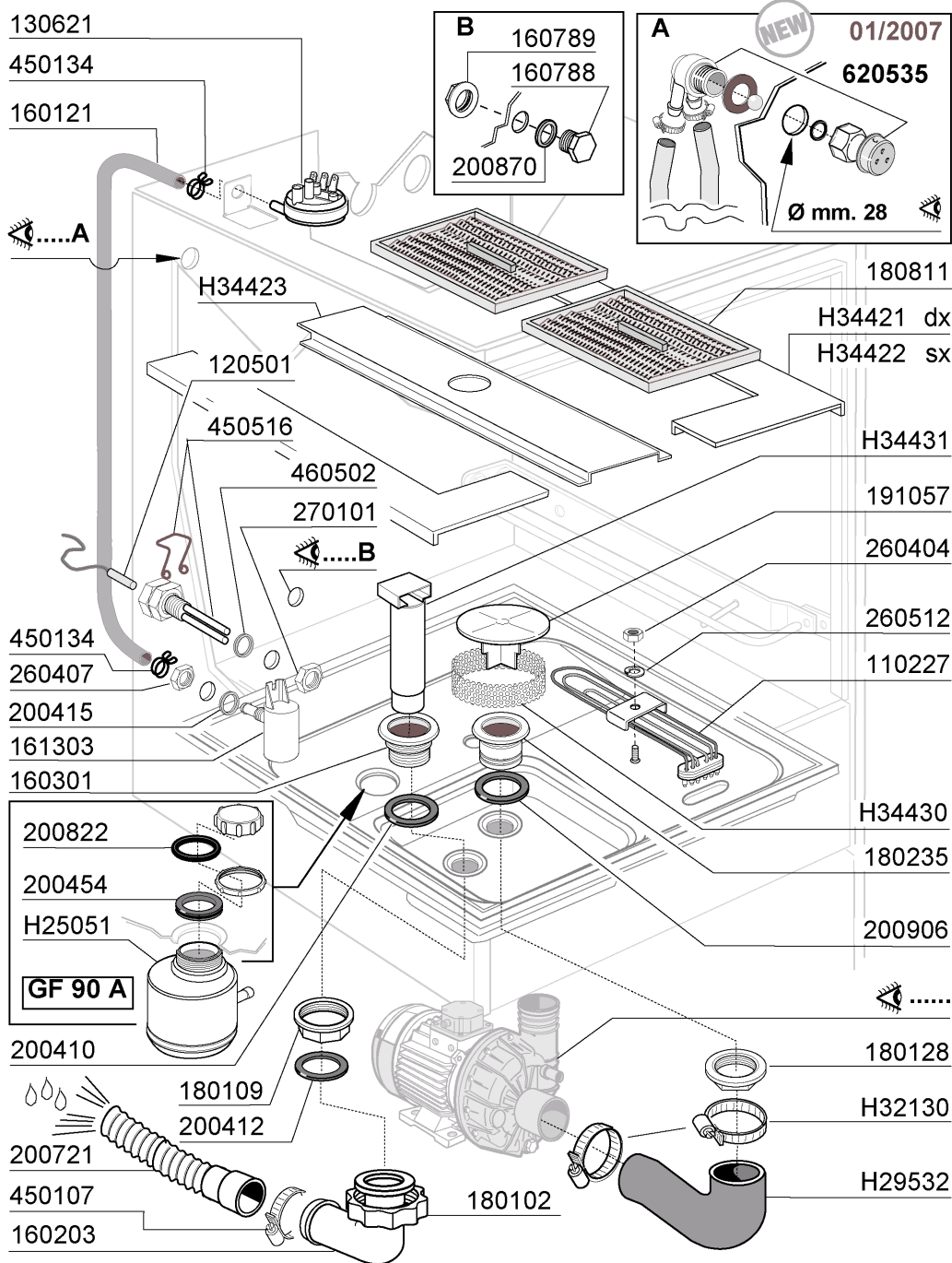

Ed. 2004

04 - 2007 | S. AG.

## 2 - Tank

CODE	DESCRIPTION
110227	HEAT. ELEMENT 3000W 230/400V
120501	THERMOSTAT 30/90°C
130621	PRESSURE SWITCH FOR BC HR 45/2
160121	HOSE EPDM D. 5 X 9
160203	ELBOW 1"1/2 N-S-F-C /DRAIN
160301	DRAIN OUTLET 1"1/2 C-S-N
160788	PLUG
160789	NUT
161303	AIR TRAP GLASSWASHER
180102	DRAIN PIPE NUT 1"1/2 F45-55
180109	LOCK NUT 1 1/2"
180128	RING NUT 65,4 C140 C85
180235	PUMP SUCTION C85-140
180811	FLAT STRAINER C34-S1600
191057	SUCTION HOSE COVER C85-C140
200410	DRAIN OUTL.WASH.1 1/2"65X47X2
200412	GASKET DRAIN 11/2" 45X33X3
200415	AIR TRAP GASKET -F2 18,5X10X3
200454	GASKET F. SALT CONT.
200721	DRAIN HOSE 28X35 2MT.
200822	PLUG GASKET OF SALT CONTAINER
200870	GASKET 18X10X2
200906	GASKET D.92X66X2
260404	STAINLESS STEEL NUTS D6 UNI 55
260407	STAINLESS STEEL NUTS D10 UNI 5
260512	ST/ST GROWER WASHER D6
270101	HEXAGON LOCK NUT 1/2"
450107	CLAMP FE ZN 38-50 H=12,2
450134	ELASTIC HOSE CLIP D.9,3/8,8
450516	THERMOSTAT SHIELD FOR 2 TERMOS
460502	GASKET 30X21X2
620535	VACUUM BREAKER
H25051	SALT CONTAINER
H29532	GF90 PUMP INLET HOSE
H32130	CLAMP
H34421	SUPPORT
H34422	SUPPORT
H34423	SUPPORT
H34430	FILTER FOR PUMP GF90
H34431	OVERFLOW PIPE GF90

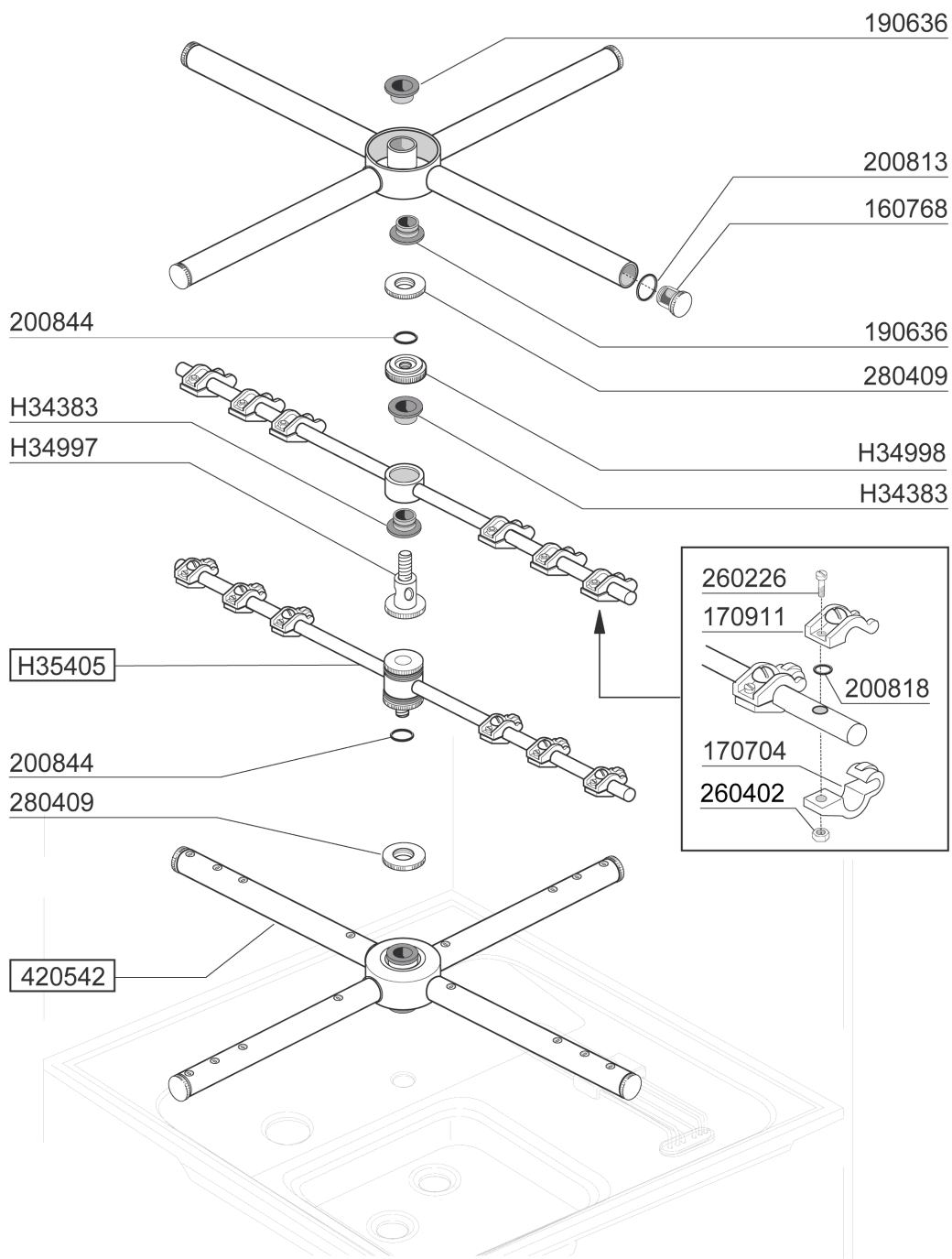

### 3 - Wash arm

CODE	DESCRIPTION
160768	PLUG FOR "C95-155" WASH ARM
170704	RINSE NOZZLE BOTTOM F-B-C33
170911	RINSE JET B23-F2-C34
190636	BUSH FOR C95-155-165 WASH ARM
200813	OR GASKET 2,21X16,36X20,78
200818	O-RING 1,78 X 6,75 X 10,31
200844	O RING 2X9,5X13,5
260226	STAINL.ST TCP SCREW 4X12 A2 UN
260402	STAINLESS STEEL NUT D4 UNI 55
280409	RETAIN.LOCK NUT CENTR.CROSS C1
420542	WASH ARM G60-100L
H34383	GF90 RINSE ARM BUSH
H34997	PIN FOR RINSE ARM GF90
H34998	RETAIN.LOCK NUT
H35405	RINSE ARM GF90

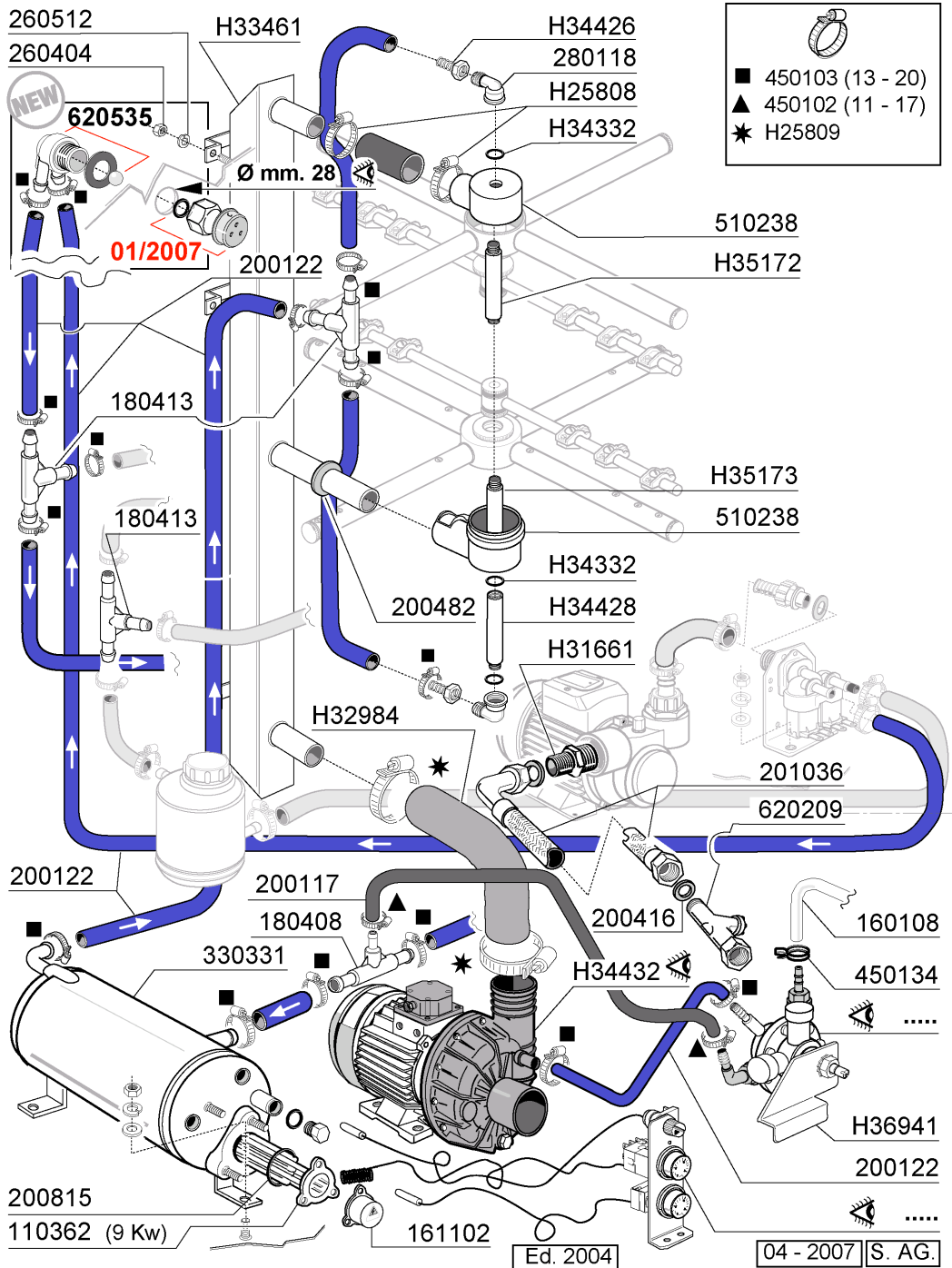

#### 4 - Wash Column

CODE	DESCRIPTION
110362	HEAT.ELEMENT 9000W 220/380V
160108	INJECT.INLET HOSE D.8X5
161102	ELEMENT COVER MOPL.
180408	TEE-NIPPLE F.INJECT.W/CENTR.RE
180413	TEE NIPPLE D.11,5 - RINSE ASSE
200117	RUBBER HOSE 7X16
200122	HOSE 11X19
200416	GASKET D. 3/4"
200482	GASKET 60X54 RAMP C140
200815	O-RING F. HEAT.ELEM.
201036	INLET HOSE 2 MT
260404	STAINLESS STEEL NUTS D6 UNI 55
260512	ST/ST GROWER WASHER D6
280118	ELL FF 3/8" - 1/4" C140-155
330331	BOOSTER (330342)
450102	CLAMP FE ZN 11-17 H=9
450103	CLAMP FE ZN. 13-20 H=9
450134	ELASTIC HOSE CLIP D.9,3/8,8
510238	NICKEL-PLATED WASH-RINSE ARM
620209	INLET WATER FILTER
620535	VACUUM BREAKER
H25808	CLAMP
H25809	CLAMP 40-64
H31661	CONNECT.1" - 3/4" MM
H32984	GF90 PUMP OUTLET HOSE
H33461	COLUMN SUPPORT
H34332	JOINT
H34426	HOSE BARB 1/4
H34428	CONNECTOR
H34432	PUMP HP2 220/380V-50HZ
H35172	UPPER ARM SUPPORT GF90
H35173	LOWER ARM SUPPORT GF90
H36941	BRACKET



5 - Rinse Assembly/Water softener

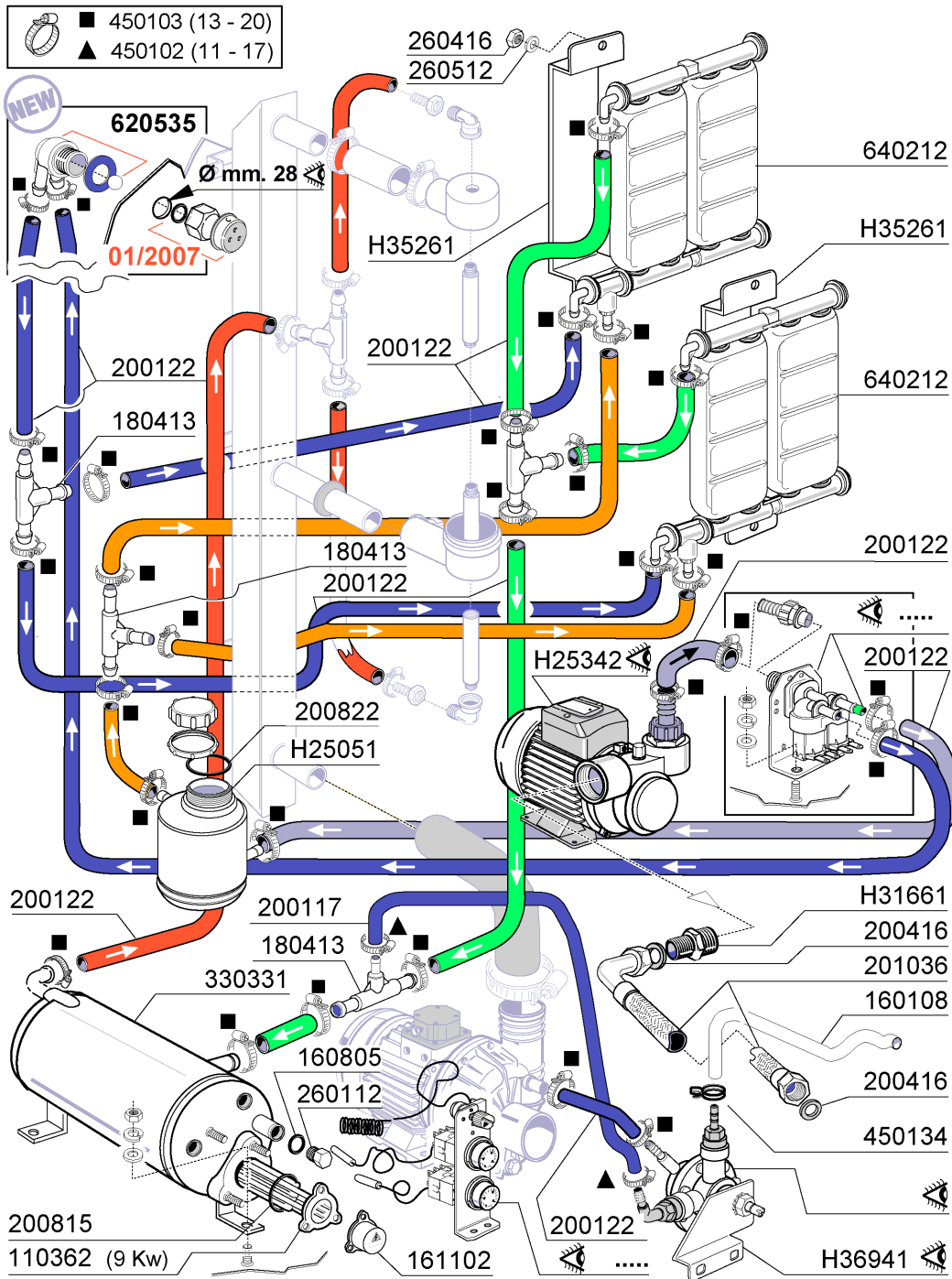

Ed. 2004

04 - 2007 | S. AG.

## 5 - Rinse Assembly/Water softener

CODE	DESCRIPTION
110362	HEAT.ELEMENT 9000W 220/380V
160108	INJECT.INLET HOSE D.8X5
160805	GASKET D.8
161102	ELEMENT COVER MOPL.
180413	TEE NIPPLE D.11,5 - RINSE ASSE
200117	RUBBER HOSE 7X16
200122	HOSE 11X19
200416	GASKET D. 3/4"
200815	O-RING F. HEAT.ELEM.
200822	PLUG GASKET OF SALT CONTAINER
201036	INLET HOSE 2 MT
260112	STAINLESS STEEL TE-SCREW 8X16
260416	STAINLESS STEEL NUTS M6
260512	ST/ST GROWER WASHER D6
330331	BOOSTER (330342)
450102	CLAMP FE ZN 11-17 H=9
450103	CLAMP FE ZN. 13-20 H=9
450134	ELASTIC HOSE CLIP D.9,3/8,8
620535	VACUUM BREAKER
640212	WATER SOFTENER FOR "F" RANGE
H25051	SALT CONTAINER
H25342	RINSE PUMP GF90
H31661	CONNECT.1" - 3/4" MM
H35261	BRACKET
H36941	BRACKET

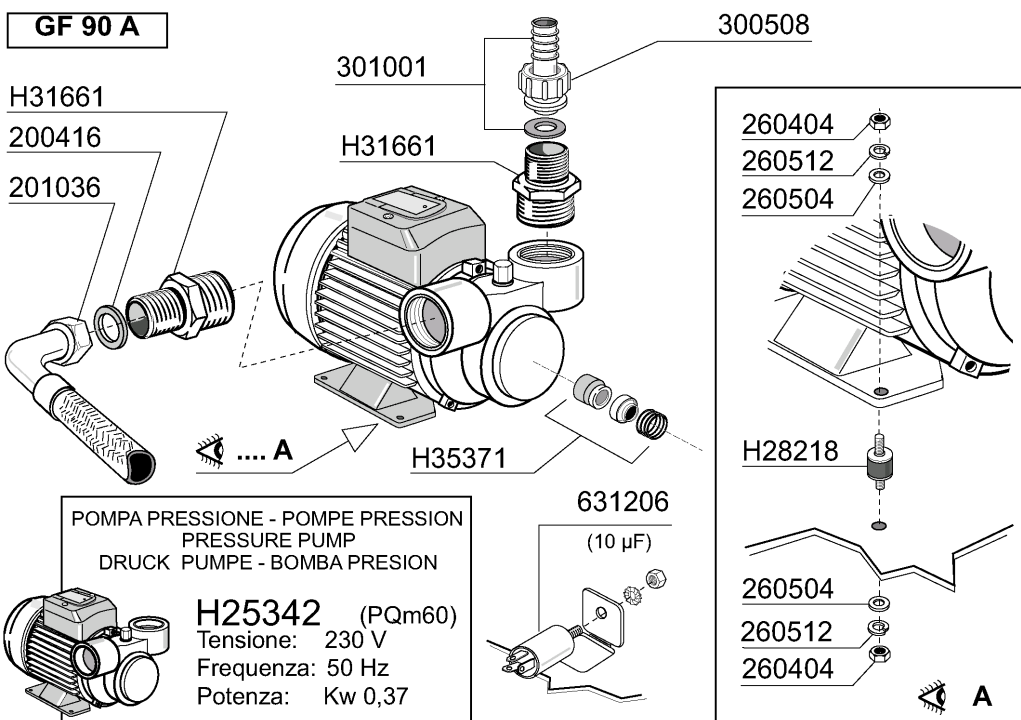
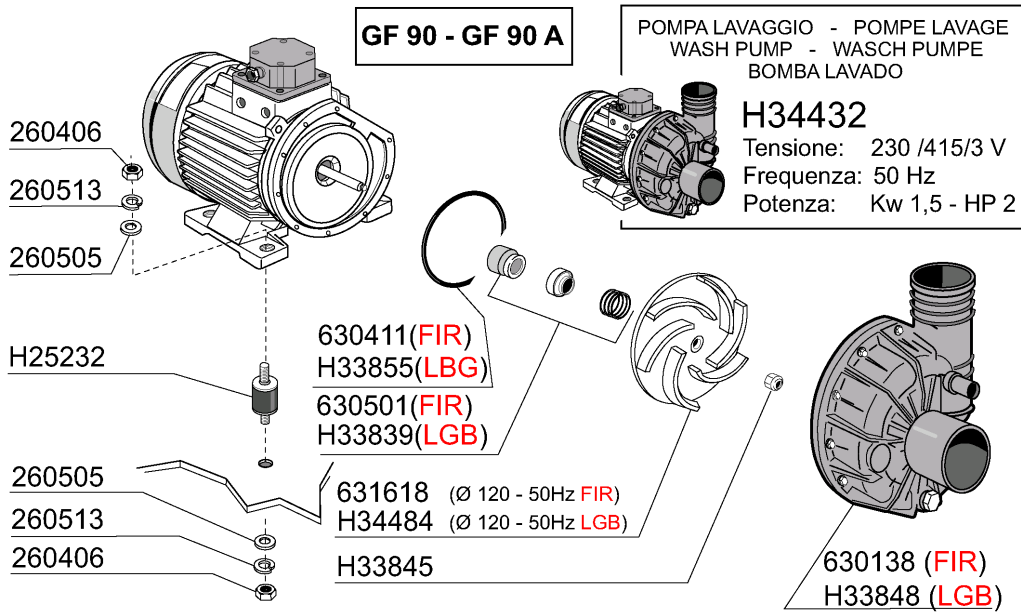

09 - 2009 | M.S.A.

**6 - Pump**

<b>CODE</b>	<b>DESCRIPTION</b>
200416	GASKET D. 3/4"
201036	INLET HOSE 2 MT
260404	STAINLESS STEEL NUTS D6 UNI 55
260406	NUT 8MA
260504	ST/ST FLAT WASHER D6
260505	STAINL.STEEL FLAT WASHER D8
260512	ST/ST GROWER WASHER D6
260513	GROWER WASHER D8
300508	LOCK NUT 3/4"
301001	NIPPLE FE-ZN 3/4"
630138	VOLUTE FOR PUMP LC
630411	O-RING PUMP FI HP 2-2,7
630501	SEAL FOR PUMP HP 2-3-3,2
631206	CONDENSER 10MF. 450V 85C
631618	IMPELLER PUMP F HP2-D.116,5
H25232	VIBRATION-DAMPING FEET GF90
H25342	RINSE PUMP GF90
H28218	PUMP FEET
H31661	CONNECT.1" - 3/4" MM
H33839	SEAL FOR PUMP GF90
H33845	SCREW FOR PUMP IMPELLER GF90
H33848	PUMP VOLUTE GF90
H33855	JOINT FOR GF90 PUMP
H34432	PUMP HP2 220/380V-50HZ
H34484	PUMP IMPELLER GF90
H35371	SEAL FOR PUMP

7 - Thermostat/solenoid valve group

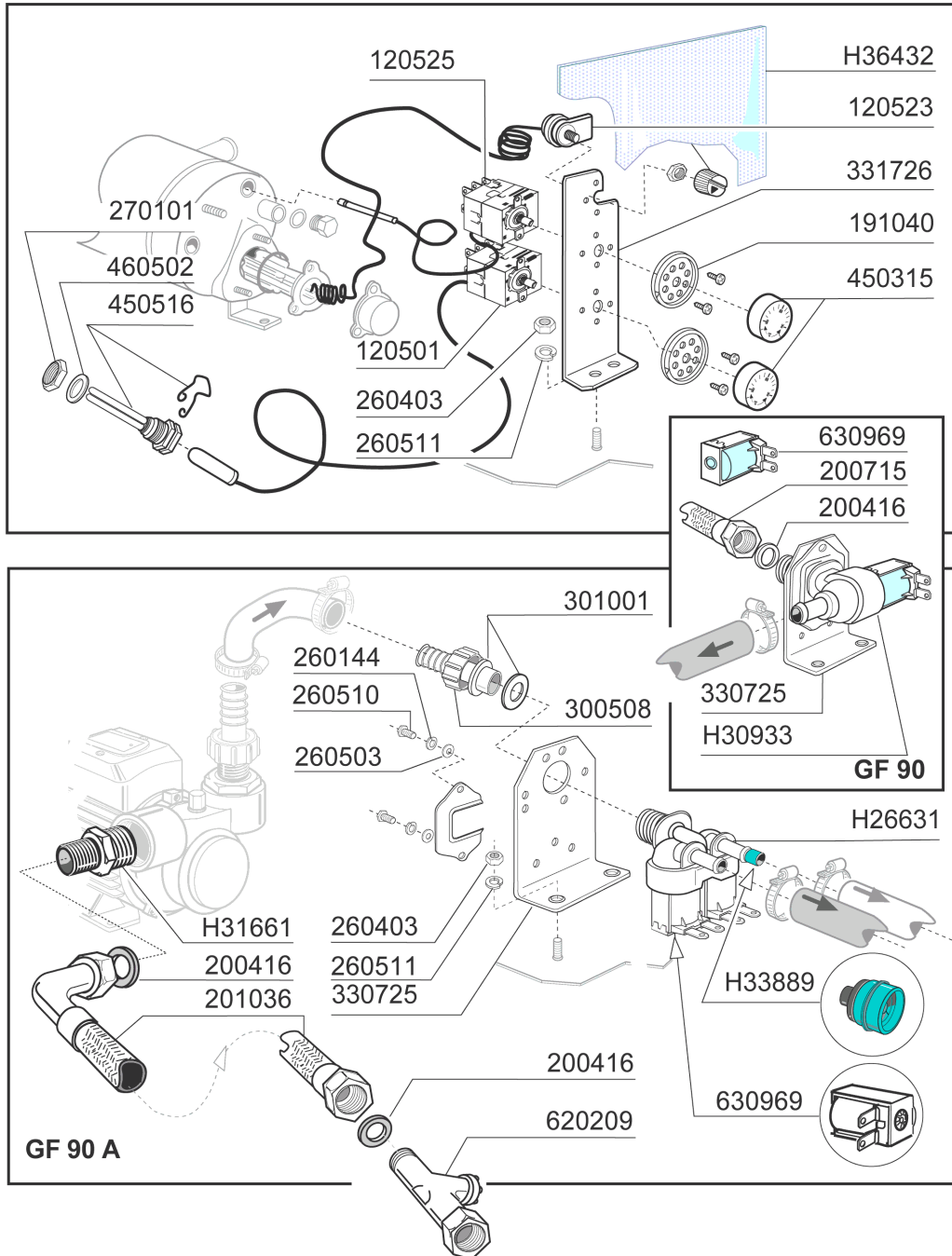

Ed. 2004

12 - 2006 | S. AG.

## 7 - Thermostat/solenoid valve group

CODE	DESCRIPTION
120501	THERMOSTAT 30/90°C
120523	SAFETY THERMOSTAT 110°C
120525	BOOSTER THERMOSTAT 2 TEMPERAT.
191040	FRAME F.THERMOSTAT KNOB
200416	GASKET D. 3/4"
200715	HOSE WATER INLET 2M STAINL.ST
201036	INLET HOSE 2 MT
260144	SCREW TE 4X6
260403	NUTS D.5
260503	STAINL.STEEL FLAT WASHER D5 UN
260510	GROWER WASHER D.4
260511	GROWER WASHER D.5
270101	HEXAGON LOCK NUT 1/2"
300508	LOCK NUT 3/4"
301001	NIPPLE FE-ZN 3/4"
330725	STANDARD BRACKET F.SOLEN.VALV
331726	BRACKET FOR 3 THERMOSTATS
450315	KNOB F. THERMOSTAT 90°C
450516	THERMOSTAT SHIELD FOR 2 TERMOS
460502	GASKET 30X21X2
620209	INLET WATER FILTER
630969	COIL S4216 220/50HZ
H26631	2-WAY SOLENOID VALVE GF90
H30933	SOLENOID VALVE AQUA+
H31661	CONNECT.1" - 3/4" MM
H33889	RIDUTT.ELETTROV.RIGENER.GF90A
H36432	COVER

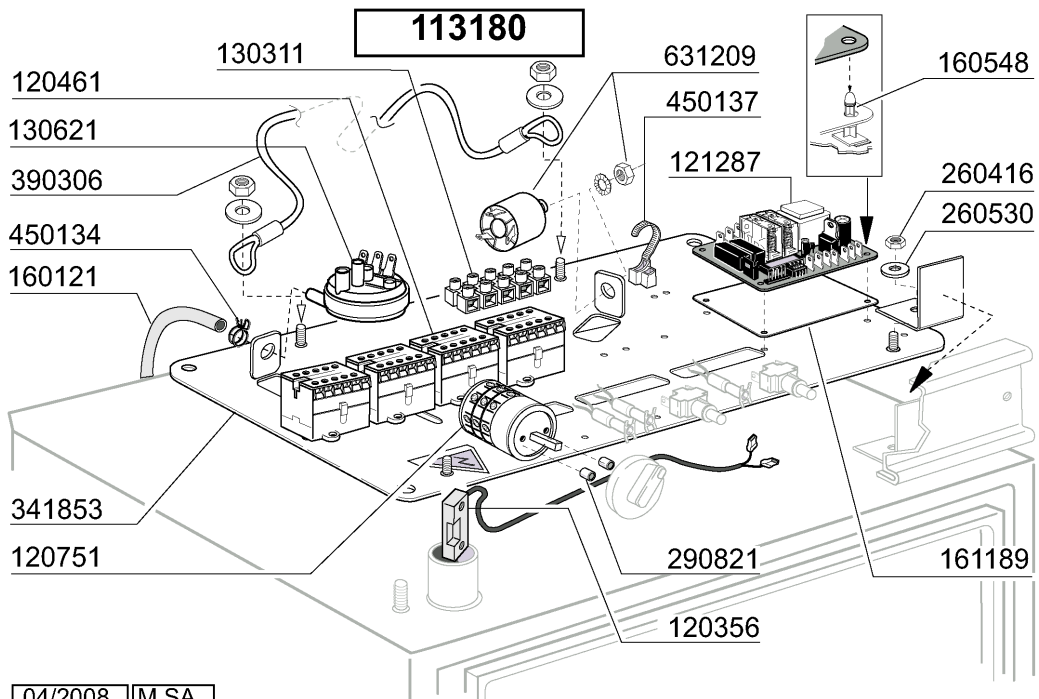
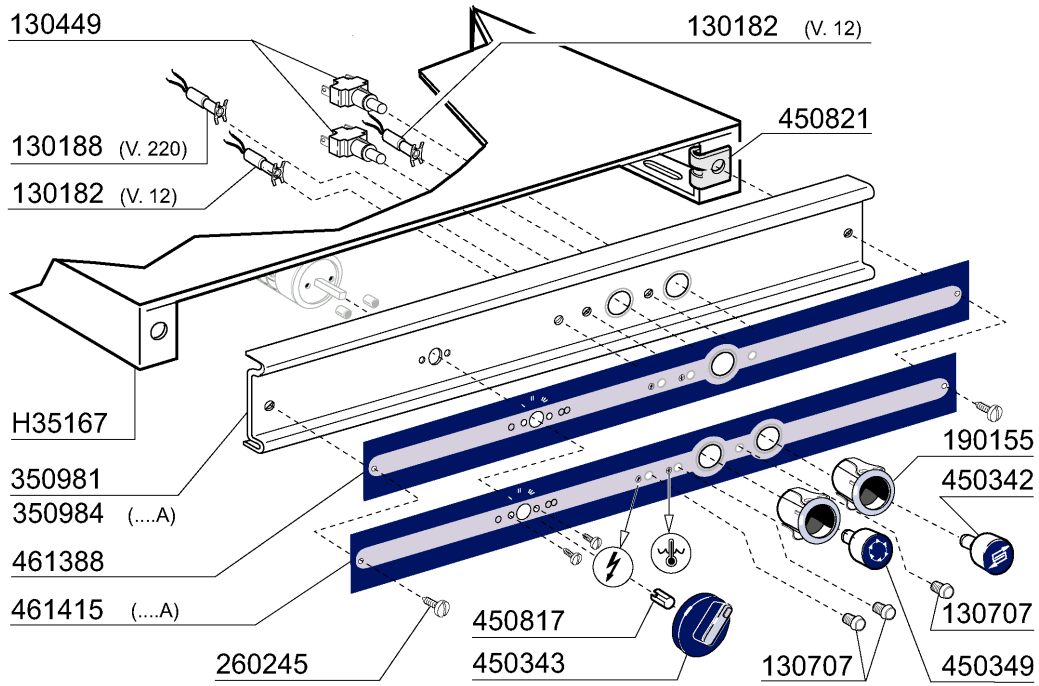

04/2008 | M.SA

## 8 - Control box

CODE	DESCRIPTION
113180	CABLE GF90 2004
120356	DOOR MAGN.SWITCH
120461	CONTACTOR ABB B6-30-01 220V
120751	4 POLE SWITCH 16A
121287	ELECTRONIC TIMER
130182	GREEN LAMP 12V
130188	GREEN LED 220V
130311	TERMINAL BLOCK
130449	PUSH BUTTON BR-BC-FC
130621	PRESSURE SWITCH FOR BC HR 45/2
130707	TRANSPARENT LENS COVERS (C-SER
160121	HOSE EPDM D. 5 X 9
160548	DISTANZ.TASTIERINI ELETTRONICI
161189	COVER
190155	BUTTON HOLDER
260245	SPECIAL SCREW TC 3,5X16
260416	STAINLESS STEEL NUTS M6
260530	STAINL.ST WASHER 7X22X2
290821	DISTANCE PIECE FOR SWITCH
341853	SUPPORT
350981	SUPPORT
350984	SUPPORT
390306	CABLE
450134	ELASTIC HOSE CLIP D.9,3/8,8
450137	COLLAR CONNECTION WITH BASE 31
450342	REGENERATION SWITCH
450343	BLUE SWITCH
450349	PUSH BUTTON ON/OFF
450817	RIVETTO ALLUM.ADV.18010406
450821	SPRING CLIP FASTENER SNU 3634
461388	CONTROL PANEL GF90
461415	CONTROL PANEL GF90A
631209	ANTI-NOISE FILTER
H35167	UPPER COVER GF90



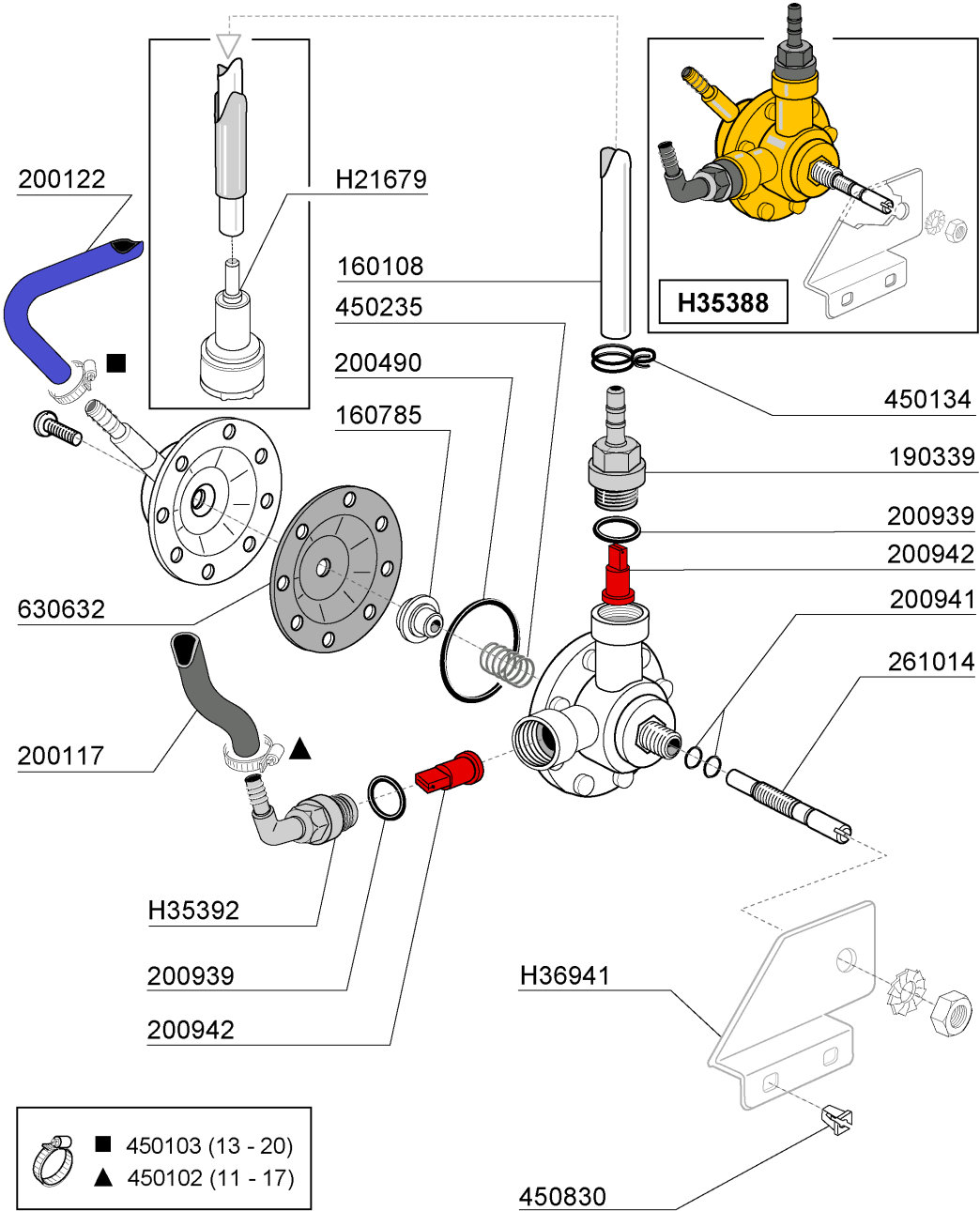

Ed. 2004

12 - 2006 | S. AG. 01

**9 - Rinse aid injector**

<b>CODE</b>	<b>DESCRIPTION</b>
160108	INJECT.INLET HOSE D.8X5
160785	GUIDE FOR SPRING RINSE AID INJ
190339	RINSE AID INJECTOR CONNECTION
200117	RUBBER HOSE 7X16
200122	HOSE 11X19
200490	PROTECTION GASKET MOD.ADV.
200939	OR GASKET
200941	OR GASKET
200942	VALVE RINSE INJECTOR HVD
261014	SCREW
450102	CLAMP FE ZN 11-17 H=9
450103	CLAMP FE ZN. 13-20 H=9
450134	ELASTIC HOSE CLIP D.9,3/8,8
450235	SPRING RINSE AID INJECTOR
450830	SCREW
630632	DIAPHRAGM RINSE INJECTOR HVD
H21679	FILTER
H35388	RINSE AID INJECTOR GF70/FC-E
H35392	NIPPLE
H36941	BRACKET

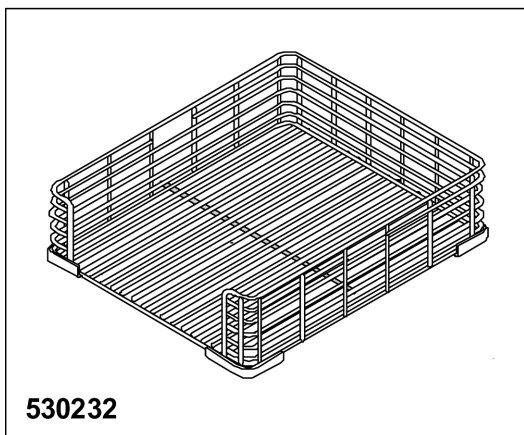

530232

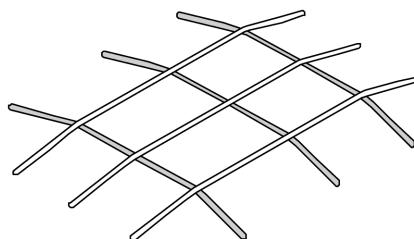

H35236

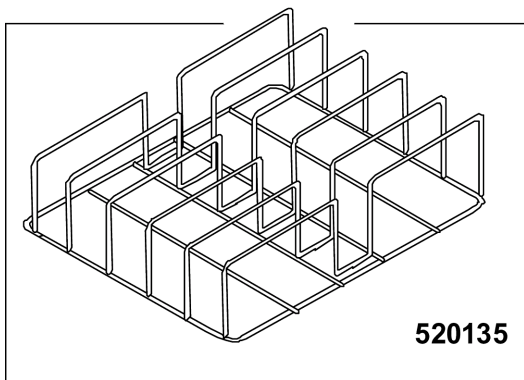

520135

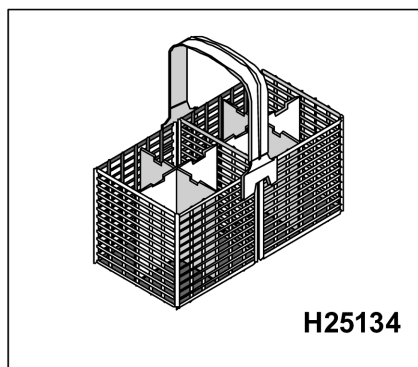

H25134

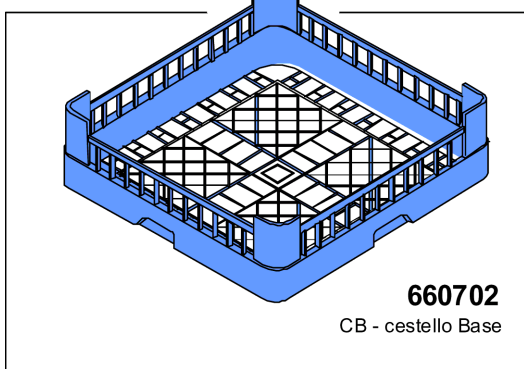

660702  
CB - cestello Base

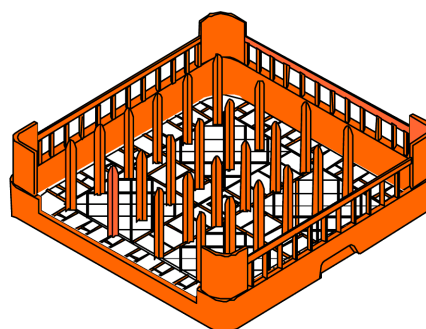

660410  
CPV - cestello 7 vassoi

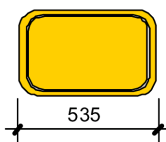

**10 - Rack**

<b>CODE</b>	<b>DESCRIPTION</b>
520135	INSERTO TEGLIE GF90
530232	BASE RACK 600X500MM
660410	CEST.VASSOI GRANDI CPV MONT.
660702	BASE RACK 50X50
H25134	CUTLERY RACK GF90
H35236	COMPARTMENT DIVIDERS GF90

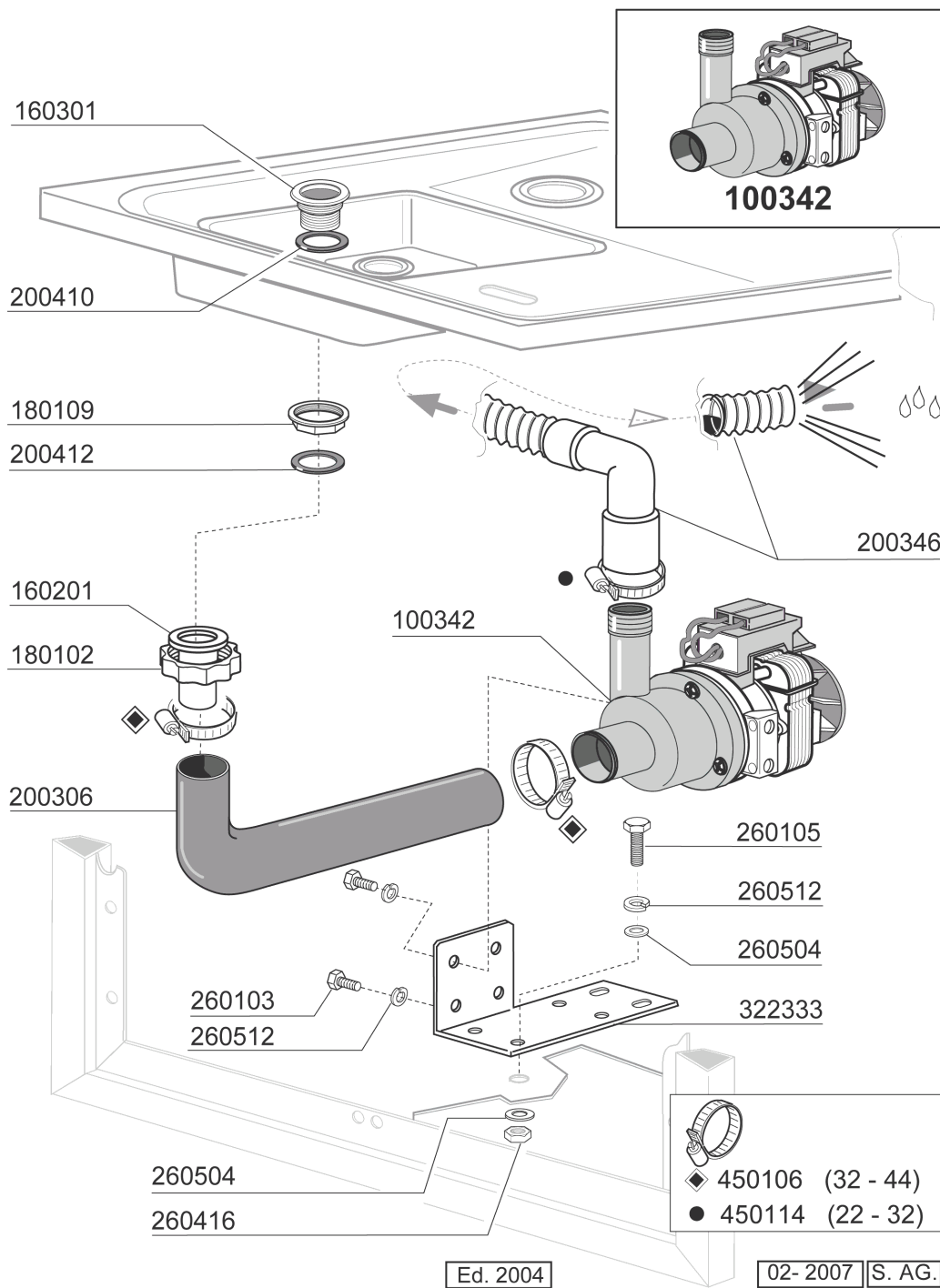

## 11 - Drain pump

CODE	DESCRIPTION
100342	DRAIN PUMP 100 W 220V
160201	ELBOW F.TANK INLET MOPLN
160301	DRAIN OUTLET 1"1/2 C-S-N
180102	DRAIN PIPE NUT 1"1/2 F45-55
180109	LOCK NUT 1 1/2"
200306	INLET HOSE 42X52 ECORINSE-DRAI
200346	DRAIN HOSE GLASSWASHER
200410	DRAIN OUTL.WASH.1 1/2"65X47X2
200412	GASKET DRAIN 11/2" 45X33X3
260103	SCREW TE 6X12
260105	SCREW TE 6X20
260416	STAINLESS STEEL NUTS M6
260504	ST/ST FLAT WASHER D6
260512	ST/ST GROWER WASHER D6
322333	HRU COVER
450106	CLAMP FE ZN 32-44 H=12,2
450114	CLAMP FE ZN.22-32 H=12,2